

# RC6704

## Triple Fixed Gain Video Amplifier with Separate Enable Inputs

### Features

- Triple video amplifier with internal resistors to set gains to +2, +1, and -1
- Independently enabled amplifiers
- 60 MHz -3 dB Bandwidth ( $A_V = 2$ )
- 20 MHz  $\pm 0.1$  dB gain flatness
- 0.06% differential gain ( $A_V = 2$ ,  $R_L = 150\Omega$ )
- 0.06° differential phase ( $A_V = 2$ ,  $R_L = 150\Omega$ )
- High CMRR (75 dB), High PSRR (70 dB)
- Dual  $\pm 5V$  power supply
- Low offset 2.0 mV
- 16-pin narrow SOIC package
- 300 V/ $\mu s$  slew rate
- Fast settling time: 0.1% in 35 ns
- Voltage gain accuracy better than 0.5%
- TTL or CMOS compatible enable inputs

### Applications

- RGB amplifier
- 3:1 crosspoint switch
- RGB switch
- Video instrumentation amplifier
- Selectable gain amplifier
- Programmable filter
- Active filter

### Description

The RC6704 consists of three low power, wide band voltage feedback operational amplifiers. Internal thin-film gain setting resistors provide gains of +2, +1 and -1. Each channel is capable of delivering a load current of at least 35mA.

Each amplifier can be independently enabled or disabled with a TTL or CMOS signal. When disabled, the amplifier is in a high impedance output state, presenting a very high input to output isolation. The layout is optimized for low channel to channel crosstalk.

The amplifiers are optimized for video applications where low differential gain and low phase distortion are significant requirements.

### Block Diagram

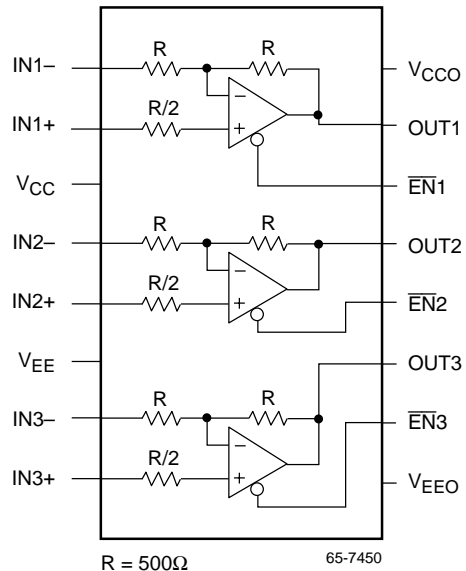

## Pin Assignments

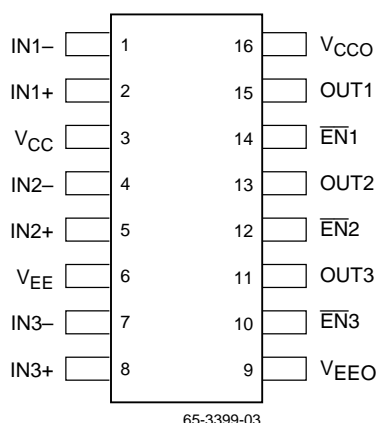

65-3399-03

## Pin Definitions

Pin Name	Pin Number	Pin Function Description
$\overline{\text{EN}}1$	14	Enables amplifier 1 when low
$\overline{\text{EN}}2$	12	Enables amplifier 2 when low
$\overline{\text{EN}}3$	10	Enables amplifier 3 when low
IN1-	1	Amplifier 1 inverting input
IN1+	2	Amplifier 1 non-inverting input
IN2-	4	Amplifier 2 inverting input
IN2+	5	Amplifier 2 non-inverting input
IN3-	7	Amplifier 3 inverting input
IN3+	8	Amplifier 3 non-inverting input
OUT1	15	Amplifier 1 output
OUT2	13	Amplifier 2 output
OUT3	11	Amplifier 3 output
VCC	3	Analog positive supply
VCC0	16	Positive supply for output stages
VEE	6	Analog negative supply
VEE0	9	Negative supply for output stages

## Absolute Maximum Ratings

(beyond which the device may be damaged)<sup>1</sup>

Parameter	Min.	Max.	Units
Positive power supply, VCC		7	V
Negative power supply, VEE		-7	V
Differential input voltage	$\text{VEE} + 2.0$	$\text{VCC} - 2.0$	V
Operating Temperature	0	+70	°C
Storage Temperature	-40	+125	°C
Junction Temperature		150	°C
Lead Soldering Temperature (10 seconds)		300	°C
Operating Temperature	0	+70	°C

Short circuit tolerance: No more than one output can be shorted to ground.

### Note:

- Functional operation under any of these conditions is NOT implied. Performance and reliability are guaranteed only if Operating Conditions are not exceeded.

## Operating Conditions

Parameter	Min.	Typ.	Max.	Units
VCC   Power Supply Voltage	4.75	5.0	5.25	V
VEE   Negative Supply Voltage	-4.75	-5.0	-5.25	V
$\theta_{\text{JA}}$   SO16 thermal resistance		105		°C/W

## DC Characteristics

$V_{CC} = 5V$ ,  $V_{EE} = -5V$ ,  $A_v = 2$ ,  $R_{LOAD} = 150\Omega$ ,  $T_A = 0^\circ C$  to  $70^\circ C$ , unless otherwise specified.

Parameter	Conditions	Min.	Typ.	Max.	Units	
VOS	Input Offset Voltage	No Load		$\pm 2$	$\pm 5$	mV
$\Delta V_{OS}/\Delta T$	Offset Voltage Drift <sup>1</sup>			$\pm 12$	$\pm 50$	$\mu V/^\circ C$
I <sub>B</sub>	Input Bias Current			$\pm 2$	$\pm 10$	$\mu A$
$\Delta I_B/\Delta T$	Input Bias Current Drift <sup>1</sup>			$\pm 10$	$\pm 50$	nA/ $^\circ C$
R <sub>in</sub>	Input Resistance <sup>1</sup>		1			M $\Omega$
C <sub>in</sub>	Input Capacitance <sup>1</sup>			0.5	2	pF
CMIR	Common Mode Input Range		$\pm 2.5$			V
CMRR	Common Mode Rejection Ratio	No Load	60	75		dB
PSRR	Power Supply Rejection Ratio	No Load	60	70		dB
I <sub>s</sub>	Quiescent Supply Current	No Load, Whole IC		25	35	mA
I <sub>sd</sub>	Supply Current Disabled			3	4	mA
R <sub>OUT</sub>	Output Impedance <sup>1</sup>	Enabled, at DC		0.2		$\Omega$
C <sub>OUT</sub>	Output Capacitance <sup>1</sup>	Disabled		0.5		pF
I <sub>OUT</sub>	Output Current		35			mA
V <sub>OUT</sub>	Output Voltage Swing	No Load	$\pm 2.5$	$\pm 3.0$		V
		$R_L = 150\Omega$	$\pm 2.5$	$\pm 3.0$		V
A <sub>v</sub>	Closed-loop Gain		1.99	2.0	2.01	dB
$\Delta A_v/\Delta T$	Closed-loop Gain Drift <sup>1</sup>		25			ppm/ $^\circ C$
V <sub>enh</sub>	Enable High Voltage		2.4			V
V <sub>enl</sub>	Enable Low Voltage				0.8	V
I <sub>en</sub>	Enable Input Current			3	10	$\mu A$
t <sub>off</sub>	Disable Time <sup>1</sup>			1.0		ns
t <sub>on</sub>	Enable Time <sup>1</sup>	Settling to 1%		200		ns

**Note:**

1. Guaranteed by design.

## AC Characteristics

$V_{CC} = 5V$ ,  $V_{EE} = -5V$ ,  $A_V = 2$ ,  $T_A = 0$  to  $70^\circ C$ ,  $R_{LOAD} = 150\Omega$ ,  $C_L = 10$  pF unless otherwise specified.

Parameter	Conditions	Min.	Typ.	Max.	Units
<b>Frequency Response</b>					
BW	-3 dB Bandwidth ( $A_V = 2$ ) <sup>1</sup>	$V_{OUT} = 0.4$ Vpp		60	MHz
		$V_{OUT} = 0.8$ Vpp		55	MHz
Flat	$\pm 0.1$ dB Bandwidth <sup>1</sup>	15	20		MHz
Peak	Maximum Small Signal AC Peaking <sup>1</sup>		0.4	0.7	dB
ISO	Off Isolation <sup>1</sup>	@ 5 MHz	90		dB
XTALK	Crosstalk Isolation <sup>1</sup>	@ 5 MHz, $R_{IN} = 50\Omega$	70		dB
<b>Time Domain Response</b>					
$t_{r1}$ , $t_{f1}$	Rise and Fall Time 10% to 90% <sup>1</sup>	2V Output Step	7	10	ns
$t_s$	Settling time to 0.1 % <sup>1</sup>	2V Output Step	35		ns
OS	Overshoot <sup>1</sup>	2V Output Step	6		%
US	Undershoot <sup>1</sup>	2V Output Step	1.5		%
SR	Slew Rate <sup>1</sup>	$V_{OUT} = \pm 2.0V$	200	300	V/ $\mu s$
<b>Distortion</b>					
HD <sub>2</sub>	2nd Harmonic Distortion <sup>1</sup>	$V_{OUT} = 0.8$ Vpp, @ FO = 20 MHz		-50	dB
HD <sub>3</sub>	3rd Harmonic Distortion <sup>1</sup>	$V_{OUT} = 0.8$ Vpp, @ FO = 20 MHz		-50	dB
<b>Equivalent Input Noise</b>					
NF	Noise Floor > 100 KHz <sup>1</sup>			-140	dBm
SND	Spectral Noise Density <sup>1</sup>	100 kHz to 200 MHz		10	nV/ $\sqrt{Hz}$
<b>Video Performance</b>					
DG	Diff. Gain (p-p), NTSC & PAL <sup>1</sup>	$R_L = 150\Omega$ , $V_{OUT} = \pm 1.5V$		0.06	%
DP	Diff. Phase (p-p), NTSC & PAL <sup>1</sup>	$R_L = 150\Omega$ , $V_{OUT} = \pm 1.5V$		0.06	Deg.

### Note:

1. Guaranteed by design.

## Test Circuits

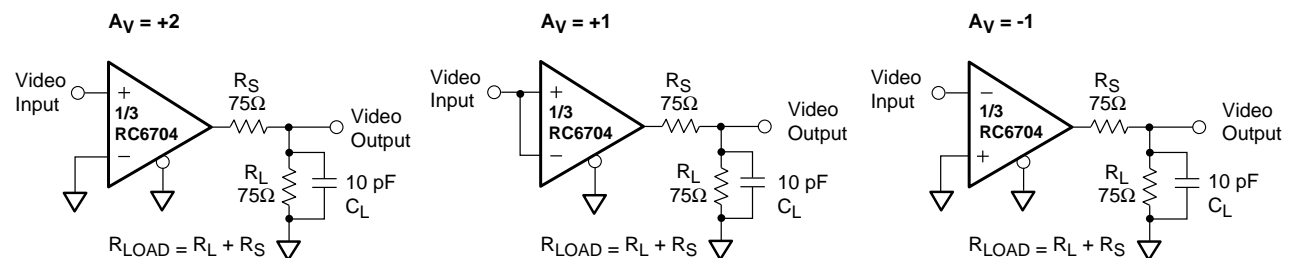

### Note:

1. When driving a 75Ω cable, the source terminator resistor must be placed as close as possible to the output of the device.

## Applications Discussion

Each of the three sections of the RC6704 is provided with an Enable input, thus the part is useful for selecting and multiplexing. It is suitable for selectable gain and programmable filter applications. A three-channel video multiplexer can be built with just one RC6704 and a decoder, as shown in Figure 1.

Note that RC6704 enable time is shorter than its disable time, hence a make-before-break action is provided, minimizing switching transients on the signal output.

An RGB switch is shown in Figure 2.

## Capacitive Load

The RC6704 can drive a capacitive load from 10 to over 100 pF. In back terminated video applications, bandwidth will only be limited by the RC time constants of the external output components. A minimum 10 pF capacitive load is required. When driving a 75Ω cable, place the 75Ω source termination resistor as close to the amplifier output as possible.

## Enable/Disable

The enable pins (10, 12, 14), when pulled to a TTL or CMOS logic low or when tied to ground, activate each amplifier individually. When pulled to a TTL or CMOS logic high, the amplifier is tri-stated and presents a high impedance at its output. When disabled the amplifier's power consumption drops, and the non-inverting input signal is isolated from its respective output.

## DC Accuracy

The RC6704 is a voltage-feedback amplifier; the inverting and non-inverting inputs have similar impedances and bias currents. To minimize offset voltage, the resistances seen by inverting and non-inverting inputs must be equal.

## Circuit Board

High-frequency applications require good grounding, power supply decoupling, low parasitic capacitance and inductance, and good isolation between the inputs to minimize crosstalk. Avoid coupling from output to input to prevent positive feedback.

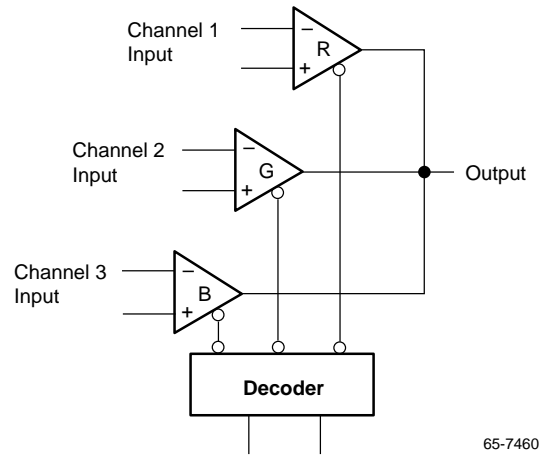

Figure 1.

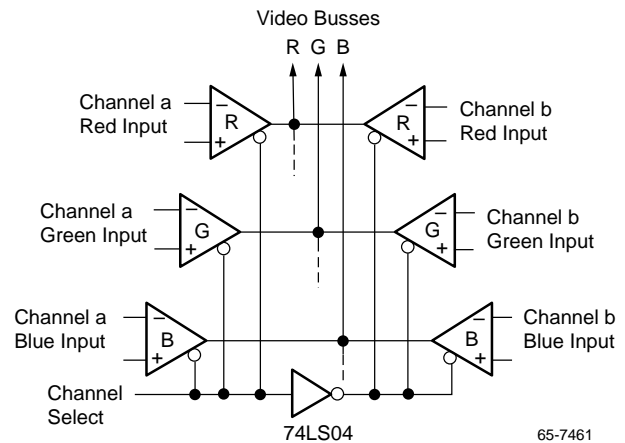

Figure 2.

**Notes**

# Mechanical Dimensions – 16-Lead SOIC Package

Symbol	Inches		Millimeters		Notes
	Min.	Max.	Min.	Max.	
A	.053	.069	1.35	1.75	
A1	.004	.010	0.10	0.25	
B	.013	.020	0.33	0.51	
C	.008	.010	0.19	0.25	5
D	.386	.394	9.80	10.00	2
E	.150	.158	3.81	4.00	2
e	.050 BSC		1.27 BSC		
H	.228	.244	5.80	6.20	
h	.010	.020	0.25	0.50	
L	.016	.050	0.40	1.27	3
N	16		16		6
$\alpha$	0°	8°	0°	8°	
ccc	—	.004	—	0.10	

**Notes:**

1. Dimensioning and tolerancing per ANSI Y14.5M-1982.
2. "D" and "E" do not include mold flash. Mold flash or protrusions shall not exceed .010 inch (0.25mm).
3. "L" is the length of terminal for soldering to a substrate.
4. Terminal numbers are shown for reference only.
5. "C" dimension does not include solder finish thickness.
6. Symbol "N" is the maximum number of terminals.

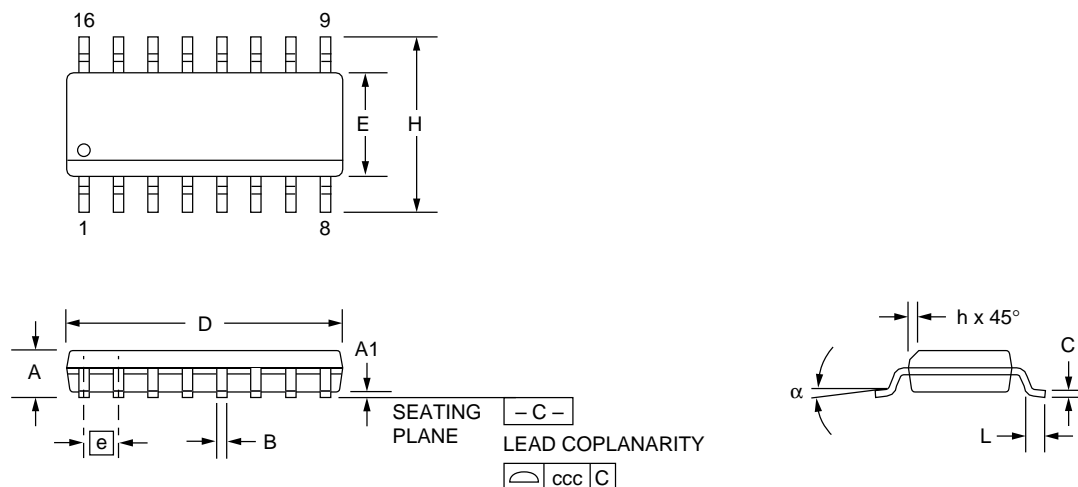

## Ordering Information

Product Number	Temperature Range	Screening	Package	Package Marking
RC6704M	0° to 70°C	Commercial	16 Pin Narrow SOIC	RC6704M

The information contained in this data sheet has been carefully compiled; however, it shall not by implication or otherwise become part of the terms and conditions of any subsequent sale. Raytheon's liability shall be determined solely by its standard terms and conditions of sale. No representation as to application or use or that the circuits are either licensed or free from patent infringement is intended or implied. Raytheon reserves the right to change the circuitry and any other data at any time without notice and assumes no liability for errors.

### LIFE SUPPORT POLICY:

Raytheon's products are not designed for use in life support applications, wherein a failure or malfunction of the component can reasonably be expected to result in personal injury. The user of Raytheon components in life support applications assumes all risk of such use and indemnifies Raytheon Company against all damages.

Raytheon Electronics  
Semiconductor Division  
350 Ellis Street  
Mountain View CA 94043  
415 968 9211  
FAX 415 966 7742